

MEUBLE VASQUE BALTIMORE

Réf. 190

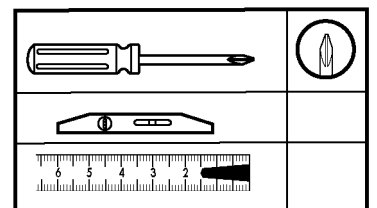
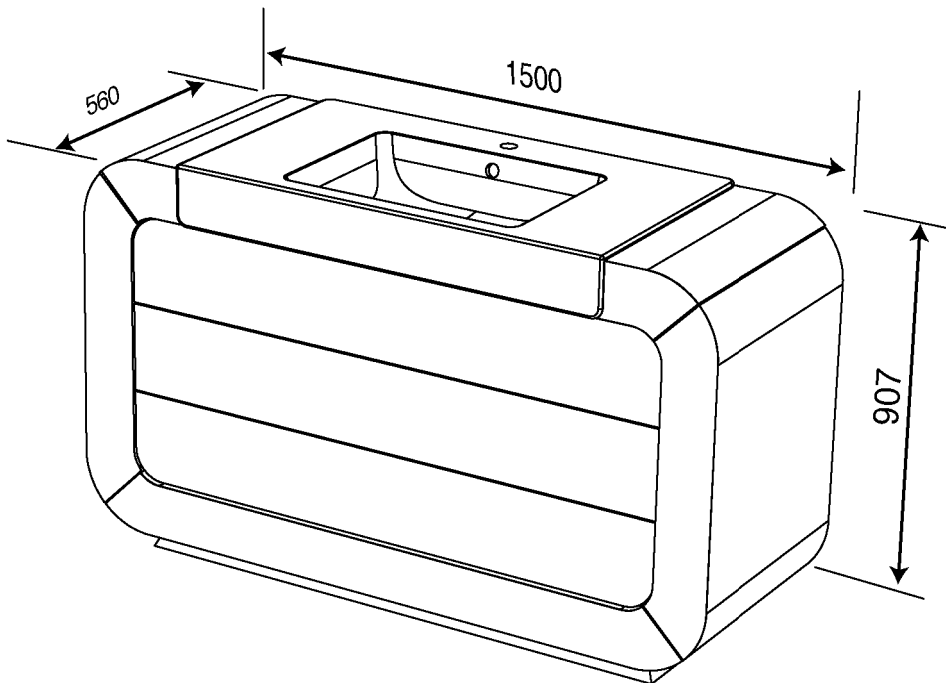

1		X 2	CHEVILLE 8
2		X 2	ROND 6 M
3		X 2	VIS 5 x 50 TR

F

- Pour accroître la longévité de vos meubles, nous vous recommandons de chauffer et de ventiler votre salle de bains pour éviter l'accumulation de vapeur et d'essuyer les projections d'eau.
- Pour votre complète satisfaction, respecter les consignes d'installation et d'entretien. Leur non respect peut entraîner la perte de la garantie.

GB

- To maximise the service life of furniture units we recommend that your bathroom is properly heated and ventilated. This will prevent the build up of excess moisture and steam stagnation. Wipe with water splashes as they occur with clean cloth.
- For your complete satisfaction carefully read the installation and maintenance instructions provided and retain for reference. Failure to follow the instructions may invalidate the product warranty.

D

- Um eine lange Lebensdauer Ihrer Möbel sicherzustellen, empfehlen wir, das Badezimmer zu heizen und zu lüften, um hohe Luftfeuchtigkeit zu vermeiden. Wasserspritzer sollten trockengewischt werden.
- Damit das Möbelstück Sie vollstens zufriedenstellt, beachten Sie bitte die Installations- und Pflegevorschriften. Bei Nichteinhaltung erlischt der Garantie Anspruch.

DECOTEC
P A R I S

3, boulevard Voltaire - 75011 Paris Tél. 01 53 36 15 00 - Fax 01 43 38 20 69

1 EMPLACEMENT AU MUR, ARRIVÉE D'EAU + VIDAGE AU SOL

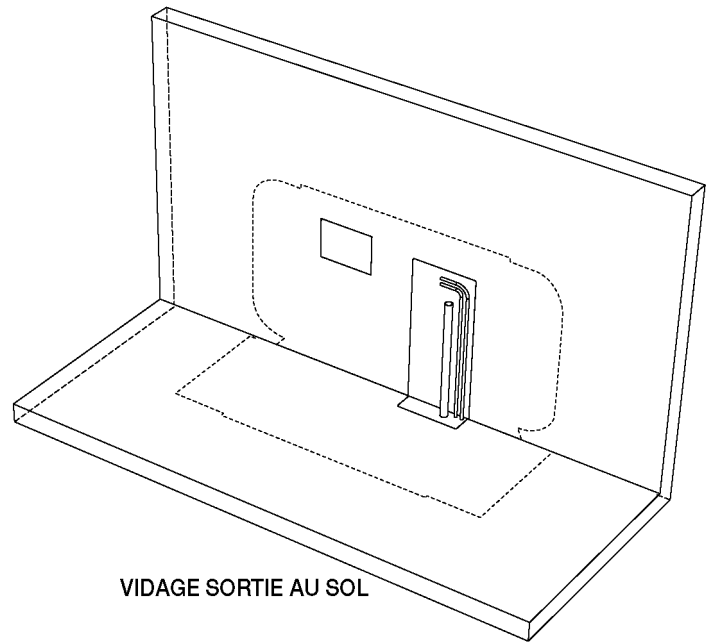
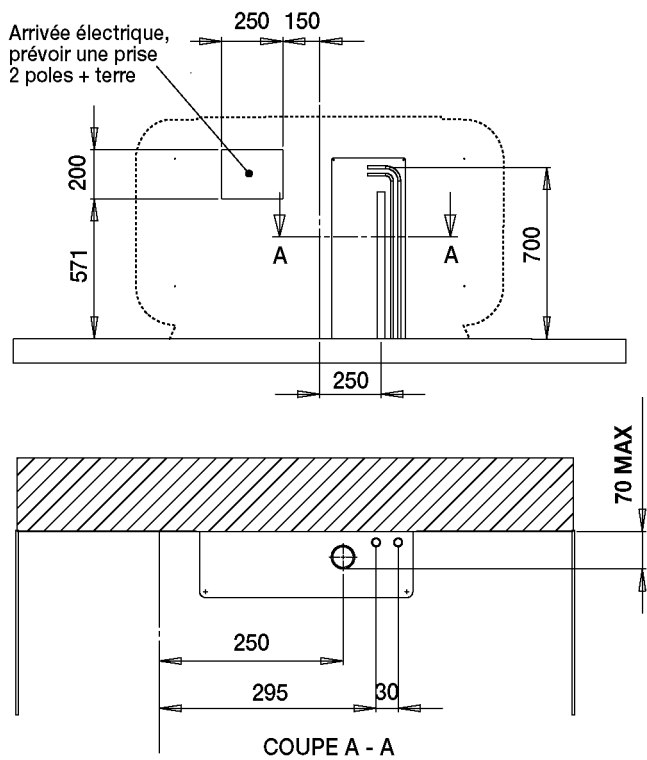

1 EMPLACEMENT AU MUR, ARRIVÉE D'EAU + VIDAGE SORTIE MURALE

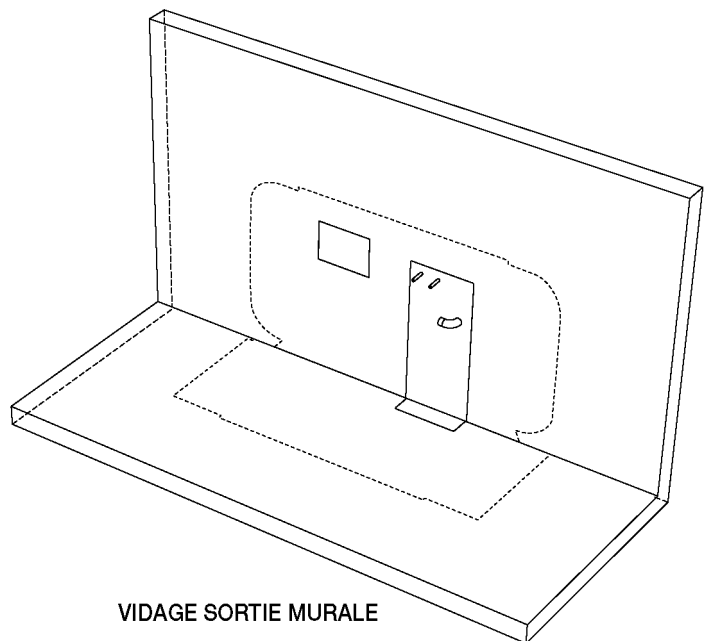
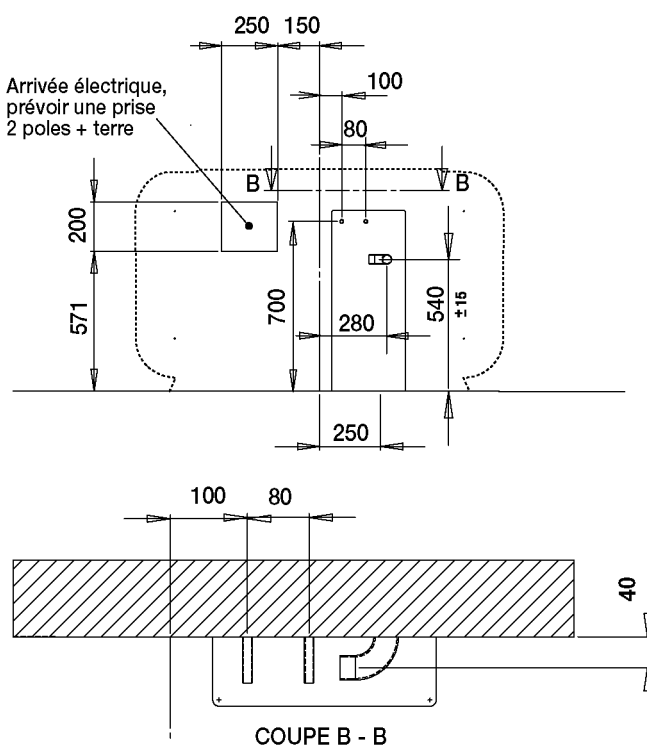

2

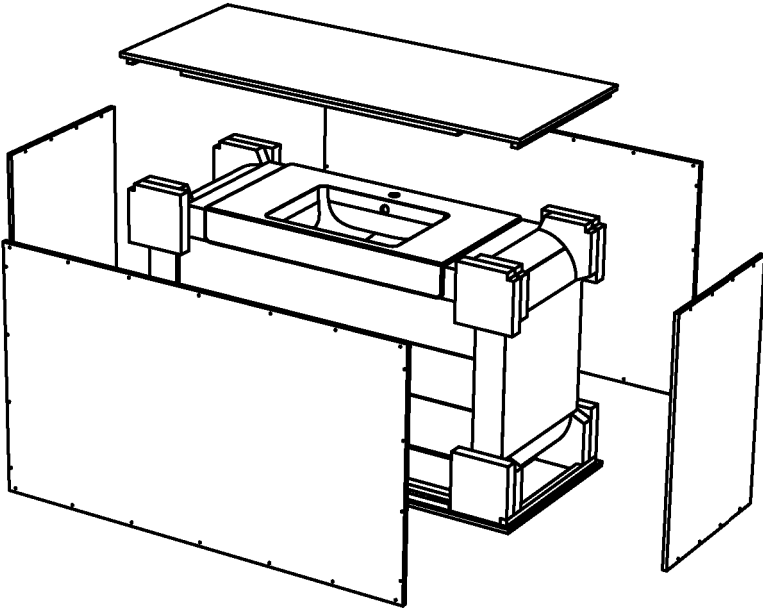

3

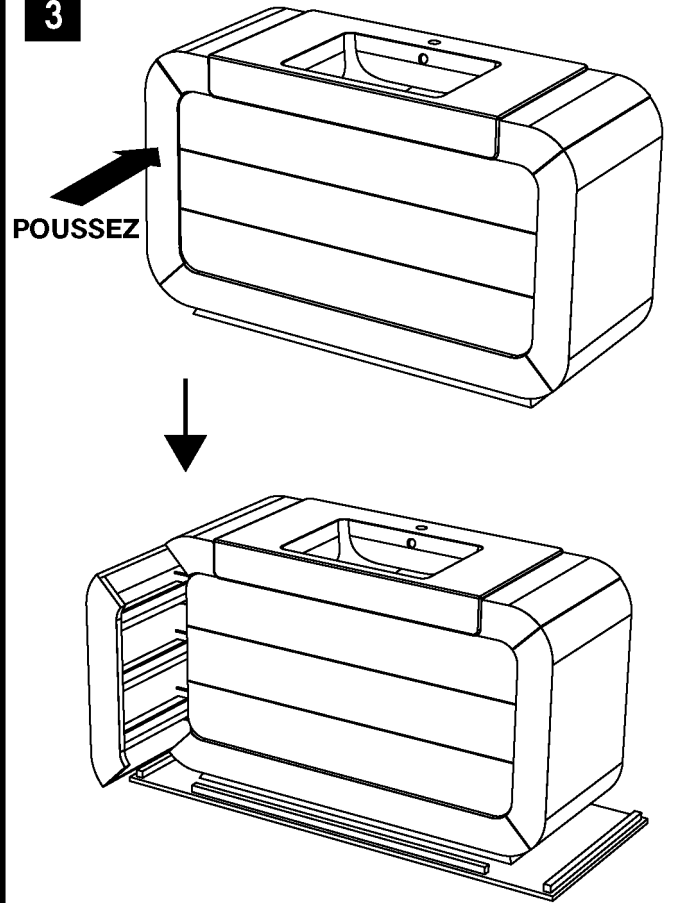

4

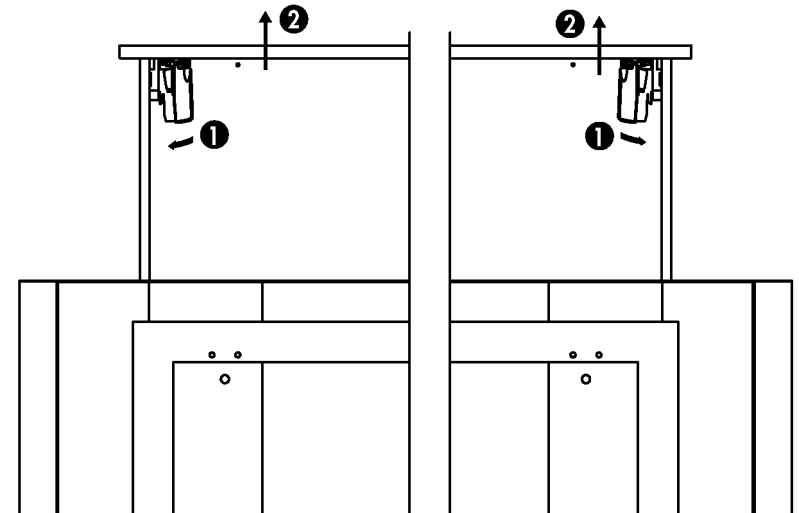
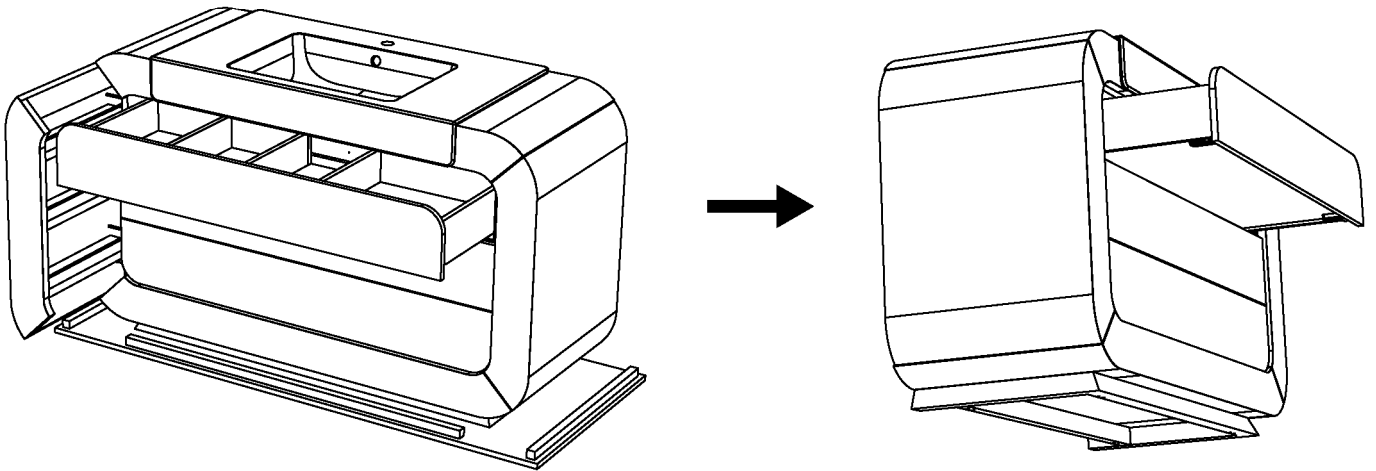

5

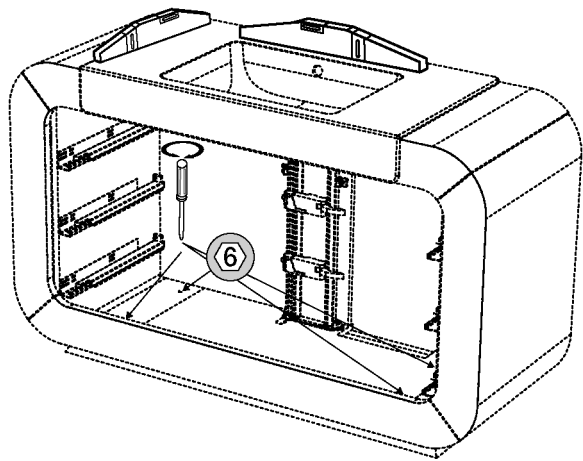

6

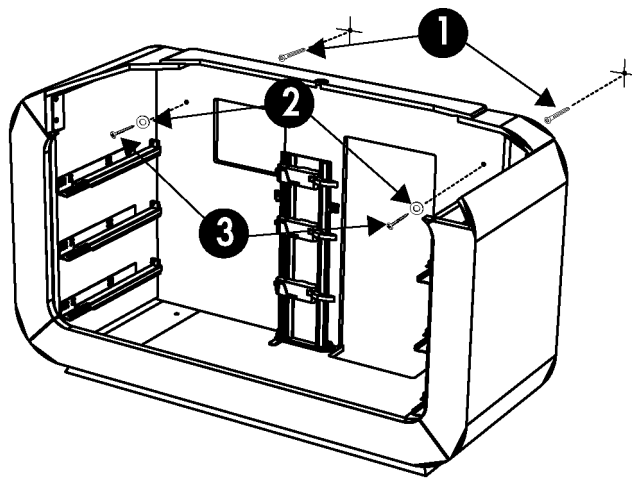

7

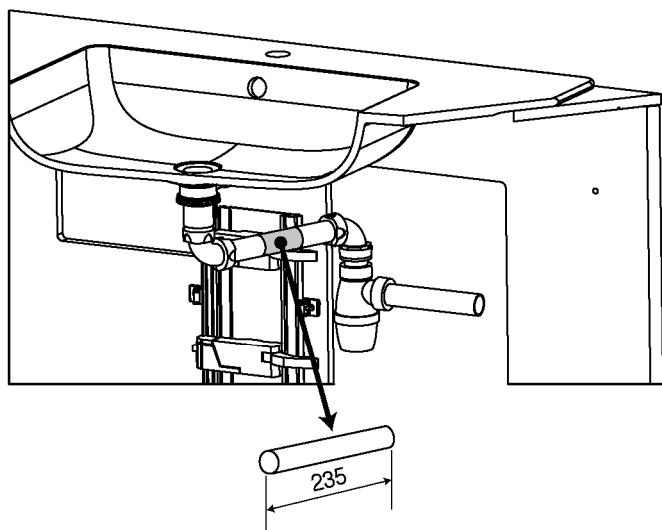

8

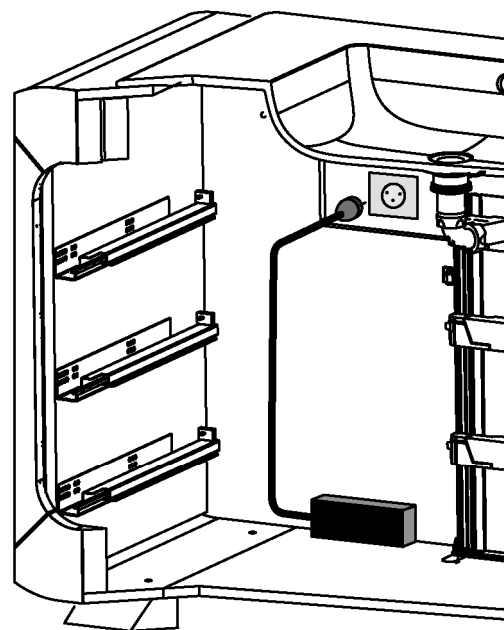

9

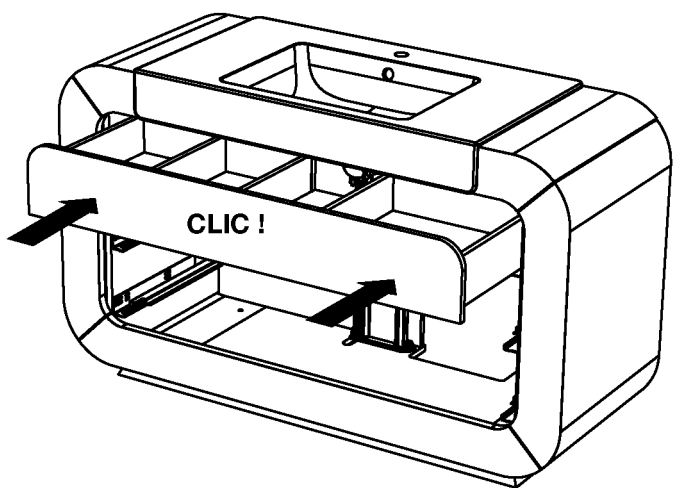

10

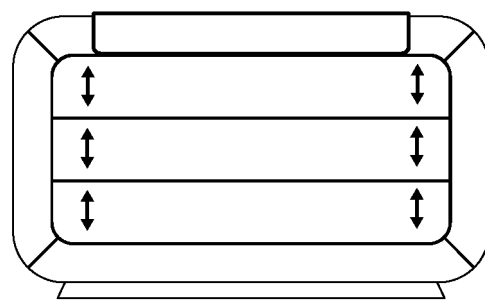

- Vous pouvez également ajuster la hauteur (uniquement) à l'aide des cames de réglage des pinces de coulisses.

